



User Guide

YDR323



※ The functions and design of this product can be changed without prior notice for quality improvement.

Do not install the product in the outdoor environment.



Do not attempt to disassemble the unit by yourself. That can cause an electronic shock and product damage.



Do not spray water directly to the product or wipe it with chemical substances such as benzene, thinner, or alcohol when cleaning the product.

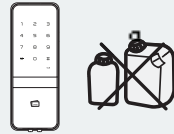

Do not force with a tool.

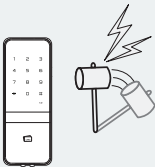

Be careful not to let any unauthorized users discover your PIN Code. Please keep your PIN Code safe.



Make sure the door is securely locked whenever you leave your house, especially in the manual lock mode.



Keep foreign materials away from the Card Key Sensor to maintain it cleanly and do not use it with wet fingers.



1 **Advance Mode**

Advance Mode can be used for professional and high secure management.

2 **Magic Mirror**

A magic Mirror function is applied, which the keypad number appears on the Mirror as soon as a user touches the product. The user can check the rear through the Magic Mirror, so that security can be enhanced.

3 **Safe Knob**

Only if a user pushes the two safe buttons simultaneously affixed to the thumb-turn knob, the user can turn the thumb-turn knob. Its security is improved compared to normal knob.

4 **Modern & Thin design**

It is the Solid and thin design using digital keypad on a solid base.



5 **High Temperature Alarm**

When there's fire, it detects the temperature of the inside. It not only goes off an alarm but also releases the lock status automatically.

6 **Remote Control** (Option)

You can use the Remote Control by installing the applicable remote control module. This option may not available depending on your country or local dealer.

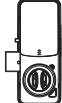
Basic Contents

- User Guide
 - Installation Template
 - Card Keys (4EA)
 - Screws
 - Batteries
- 

- Front Body
 - Back Body
 - Strike
 - Holder Door 15, 35mm

Optional Accessory (purchase separately)

- Remote Control
- Remote Control Module

Specifications

Parts	Specifications	Remarks
Front Body	13(D) x 66(W) x 179(H)	Operating temperature : -15~55°C
Back Body	36(D) x 72(W) x 185(H)	
Battery	4EA 1.5 AA alkaline batteries (Operating voltage: 4.5 ~ 6V)	Last up to 1 year (10 times used a day)

! The durability depends on the battery life and the frequency of use.
The color of the product may change if it is under the direct light for a long time, and it is not a defect.

Front Body

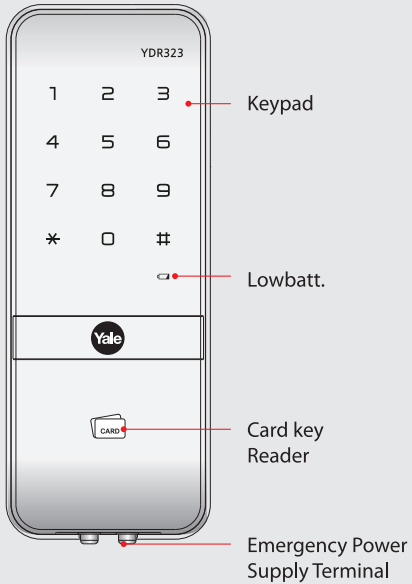

Keypad

Lowbatt.

Card key Reader

Emergency Power Supply Terminal

Back Body

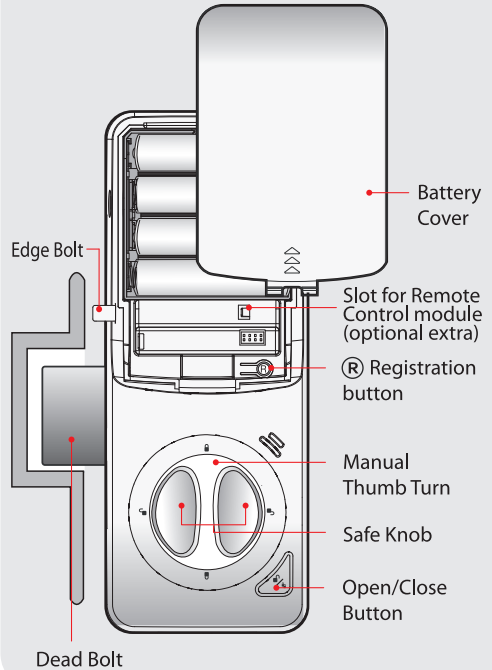

Battery Cover

Slot for Remote Control module (optional extra)

Ⓜ Registration button

Manual Thumb Turn

Safe Knob



Open/Close Button

Dead Bolt

To Use User PIN Code

Registering User PIN Code

User PIN Code should be set Within 4 to 12 digits. [*] and [#] are not allowed.

Press  (Registration) button → Enter User PIN Code (4 to 12 digits) → Press  (Registration) button



Open Door with User PIN Code

Touch The Keypad → Enter User PIN Code (4 to 12 digits) → Touch with palm or Press [*] button to end

To Use Card Key

Registering Card Keys

* You can register up to 40 card keys.

Press  (Registration) button → Contact **all the keys** you wish to register on one by one → Press  (Registration) button

Open Door with Card key



Contact Card Key.

Caution



- Keep the door open while you register Card Key to prevent yourself from accidentally getting locked out.
- The previously registered Card Key will automatically be deleted when the new Card Key is registered.
- Please use the only provided RF Cards in the package for security.

Lock Door

To Close Door from Outside

Step	Icon	Description
Manual Lock status		Touch the keypad in the front body gently with your palm to lock a door.
Auto Lock status		The built-in Auto Lock sensor automatically locks a door within 5 seconds after closing the door.

To Close Door from Inside

Step	Icon	Description
Manual Lock status (The default setting)		Turn the manual thumb turn to unlock pressing buttons together.
		Press Open / Close button.
Auto Lock status		The built-in Auto Lock sensor automatically locks a door within 5 seconds after closing the door.

Forced Lock

Outside Forced Lock Setting - PIN Code

Touch with palm → Enter User PIN Code → Enter [#] button for 3 seconds

Outside Forced Lock Setting - Card Key

Contact Card Key for 3 seconds until you hear 3 beeps.

! - If compulsory external lock is setup, the door open/close button will not function. The alarm will go off if one tries to open the door through the manual opening/closing unit.

Inside Forced Lock Setting

Set

Press the Open / Close button for 5 seconds. Until you hear 3 beeps.

Release

Press the **(R)** Registration button or, Turn the manual thumb turn to **pressing buttons together**.

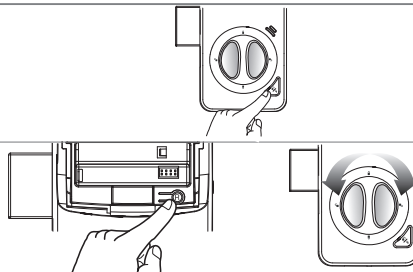

Auto / Manual Locking Mode

To Set Auto Locking Mode

* The default setting

Auto lock setting locks a door in 5 second after the door was closed.

Press **(R)** (Registration) button → Enter **[#]** button → Enter number **0** and **1** on the keypad → Press **(R)** (Registration) button

! Even after a door was locked by the Auto Lock function, please check again if the door was completely locked.

To Set Manual Locking Mode

Press **(R)** (Registration) button → Enter **[#]** button → Enter number **0** and **3** on the keypad → Press **(R)** (Registration) button

! Be careful not to leave the door open at manual lock mode.

Volume Setting Feature * The default setting : High

It enables you adjust the sound volume.

Press **(R)** (Registration) button → Enter **[#]** button →

MUTE	3	,	0	→	Press (R) (Registration) button
LOW	3	,	1		
HIGH	3	,	3		

Open / Close Button Setting Feature * The default setting; enable

It enable/disable you set the Open / Close button .

Press **Ⓜ** (Registration) button → Enter [#] button → Enter number **2** and **4** on the keypad → Press **Ⓜ** (Registration) button

* The on/off of the function changes every time one sets the setting.

* When the system is set to off, the open/close button does not function.

Alarm Feature

The alarm sound continues for 30 minutes or until it is reset.

Break-in / Damage Alarm

Break-in : When someone tries to Break-in by opening a door when it is locked, the alarm will Sound.

Damage : When the front body was damaged due to forced separation or drilling, the alarm will Sound.

High Temperature Alarm

- When there's fire, it detects the temperature of the inside. It not only Sounds an alarm but also releases the lock status automatically.
- Even when the inside Lock mode is set, the High Temperature Alarm releases the lock status automatically.

3-minute Lock Feature

If incorrect security codes or unregistered Card Keys are attempted 5 times in a row, it will lock out for about 3 minutes with the blinking LED.

To Release 3-minute Lock

- Method 1** Press the Open / Close button.
- Method 2** Press the Back Body (R) button.
- Method 3** Open with a Safe Thumb Turn.

Open Door with Fake PIN Code

This is an security measure to prevent your PIN Code being accidentally exposed.

- Method 1** Touch with palm ➔ Press **Any button** ➔ Press **PIN Code** ➔ Touch with palm
- Method 2** Touch with palm ➔ Press **PIN Code** ➔ Press **Any button** ➔ Touch with palm

- * 3-minute Lock mode won't affect any alarm and is sustained even after the product is rebooted.
- * Once 3-minute Lock mode is on the Fake PIN Code will not work until the next normal verification (Card key verification, User PIN Code, open door from inside).

Remote Control Module

Buy the Remote Control Module and install it to link the Remote Control.

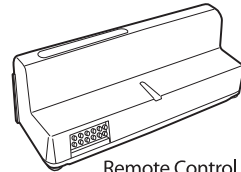

Remote Control Module

Install Remote Control Module

1 Remove batteries

Open the battery cover in the Back Body and remove all batteries.

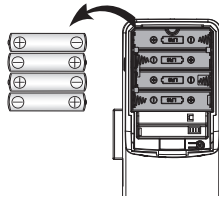

2 Install Remote Control Module

Equip the Remote Control Module to the connector.

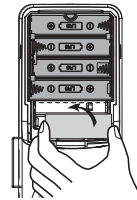

3 Insert batteries

Insert all the batteries by checking the \oplus , \ominus connector.

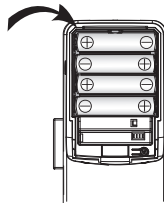





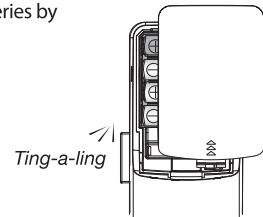







4 Insert batteries

Insert all the batteries by checking the connector.













Remote Control

To Register Remote Control





Step	Icon	Description
1 Press  (Registration) button and 	 	Open the battery cover in the Back Body. Press  (Registration) button and then  .
2 Enter number 0 and 5 on the keypad	 	Enter number 0 and then 5 on the keypad.
3 Register Remote Control		Press the SET button on the Remote Control. (Up to 5 Remote Controls)
4 Press  (Registration) button		Press the  (Registration) button in the Back Body again to complete the procedure.

To Release Remote Control

Step	Icon	Description
1 Press  (Registration) button and 	 	Open the battery cover in the Back Body. Press  (Registration) button and then  .
2 Enter number 7 and 5 on the keypad	 	Enter number 7 and then 5 on the keypad.
3 Press  (Registration)		Press the  (Registration) button in the Back Body again to complete the procedure.

You may open a door when contacting the 9V battery.

Emergency Power Supply for Discharged Batteries

Step	Icon	Description
1 Contact the 9V Alkaline battery		Open the emergency cover. Keep contacting the 9V Alkaline battery onto the emergency power supply terminal.
2 Touch with a palm		Touch the keypad gently with your palm.
3 Enter User PIN Code		Enter each number of User PIN Code.
4 Touch with palm or Enter * button.		Touch the keypad gently with your palm or Enter * button to confirm.

Emergency Power Supply for Discharged Batteries

1 Expiry Period

The product uses four 1.5V Alkaline AA batteries. They may sustain 1 year if used 10 times a day. (Users are advised to use authentic alkaline batteries.)

2 Low Battery Alarm

You must replace all 4 batteries for the following cases:
 The Low Battery Lamp on the Front Body lights on
 The alarm melody will sound (a nursery rhyme starting with ting-a-ling melodies)

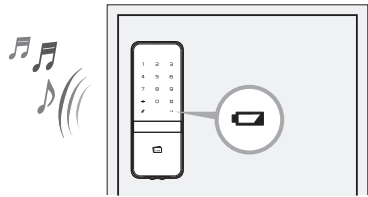

⚠ The battery life vary depending on temperature, moisture levels, Frequency of use and the quality of the batteries.



<http://www.yalelock.com>

Yale®

中文簡單說明書

YDR323



請勿裝置於戶外

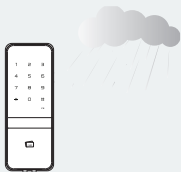

請勿任意拆卸, 重組



請勿以清水直接沖洗
產品或以化學產品擦拭

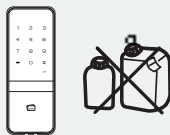

請勿以工具敲擊產品



請牢記您的密碼



當您外出時, 請務必
確認門是否已上鎖



請勿以不明材質
擦拭清潔產品



1 進階模式 (Advance Mode)

提供您更專業及更高保安的使用模式

2 智慧型鏡面觸控面板 (Magic mirror touchpad)

特殊美觀鏡面設計, 個別的數字燈號閃爍方式, 可以告知使用者如何設定各項操作功能.

3 安全手動旋鈕 (Safe Knob)

為加強防盜性能, 產品採用特殊結構的手動旋鈕技術. 從內部用手動旋鈕開啟時, 需同時按住旋鈕上兩邊按鈕才可開啟

4 超薄設計 (Modern & Thin design)

使用了超薄設計, 提高與門的統一性, 輕巧美觀

5 抗高壓電擊迴路技術 (Anti-shock)

本產品採用抗高壓電技術, 如遇高壓電衝擊則會自動切斷電路. 保護產品及加強防盜性能.

6 網路盒 (選配)

您可以使用選配的網路盒(遙控器開啟門鎖). 它可以連結至數位家庭無線安全監控系統

基本構成品

- 使用說明書
- 施工圖
- RFID卡片(四張)
- 螺絲
- 電池



· 室外部
(前面板)



· 室內部
(後半部)



· 鎖扣片

· 持有人門 15, 35mm

選購品

- 網路盒
- 遙控器

規格

Parts	Specifications	Remarks
室外部	14(D) x 72.8(W) x 186(H)	Operating temperature : -15~55°C
室內部	48.8(D) x 77.5(W) x 190.5(H)	
電池	4EA 1.5 AA alkaline batteries (Operating voltage: 4.5 ~ 6V)	電池約可使用一年 (以一天10次開關計算)

⚠ 注意

- 電池使用壽命依溫濕度, 使用頻率及產品品質有所差異
- 當您訂購時, 請檢查所有零件及配件
- 若強光, 陽光長時間直接照射本產品, 外觀顏色可能會改變。

室外部



室內部

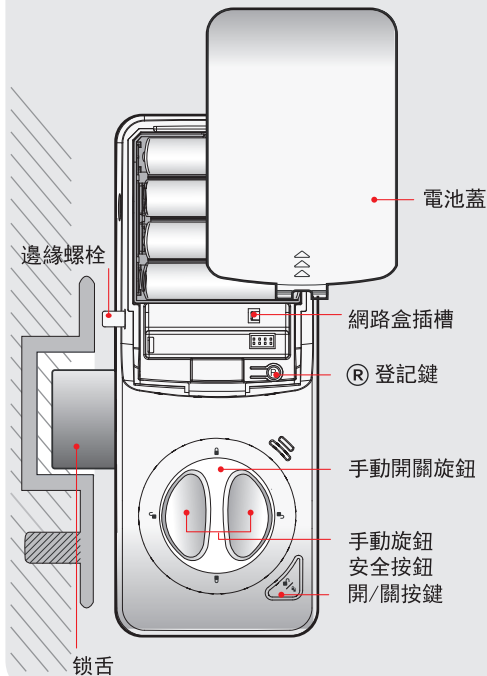

使用密碼

登記密碼

可以登記4 ~ 12位密碼, 不能使用[*]或[#]

按 **Ⓡ** 登記鍵 → 輸入要登記的密碼 (4~12位) → 再按 **Ⓡ** 登記鍵, 密碼登記完成

用密碼開啟

用手掌觸摸密碼鍵 → 輸入已登記的密碼 (4~12位) → 用手掌觸摸密碼鍵, 或者按 [*] 鍵, 即可開啟

使用卡片

登記卡片 (可以登記最多40張)

按 **Ⓡ** 登記鍵 → 把要登記的所有卡片 依次接觸到卡片感應區 → 再按 **Ⓡ** 登記鍵, 密碼登記完成

用卡片開啟



把已登記的卡片接觸到卡片感應區

⚠ 注意

- 為保證產品使用品質, 請您使用原廠提供的卡片.
- 若自行使用其他RFID卡片 (信用卡, 悠遊卡, 手機, 等), 而造成的損害, 本公司不承擔法律責任.
- 為了避免卡片遺失而影響進出, 請務必登記密碼.

鎖定功能

從外部上鎖

順序	操作	具體方法
在[手動鎖定] 狀態下		用手掌觸摸密碼鍵, 上鎖完成
在[自動鎖定] 狀態下		本產品有內嵌式感應器, 關門後5秒內, 將自動上鎖

從內部上鎖 原廠設定為[手動上鎖]

順序	操作	具體方法
在[手動上鎖] 狀態下		旋轉室內部的手動旋鈕, 上鎖完成
		按下室內部的開/關鍵, 上鎖完成
在[自動上鎖] 狀態下		本產品有內嵌式感應器, 關門後5秒內, 將自動上

強制上鎖功能

外部強制上鎖-用密碼鎖定

用手掌觸摸密碼鍵 → 在室外部觸摸密碼鍵，
輸入已登記的密碼(4~12位) → 按住 [#] 鍵3秒

外部強制上鎖-用卡片鎖定

把卡片接觸在卡片感應區3秒，聽到3聲嗶聲後，上鎖完成

! 在[外部強制上鎖]狀態下，用室內部手動旋鈕開啟時，會發出警報聲。

內部強制上鎖

設定方法

按住開/關按鈕5秒

解除方法

按 **Ⓡ** 登記按鈕，
或者旋轉手動旋鈕

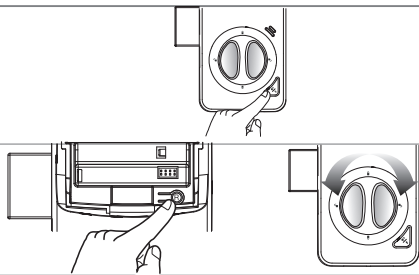

自動/手動上鎖設定

自動上鎖設定

原廠設定為[手動上鎖]

在[自動上鎖狀態]下, 正常關門後, 5秒內將自動鎖定

按 **Ⓡ** 登記鍵 → 在室外部觸摸密碼鍵, 輸入 [#] 鍵 → 在室外部的密碼鍵, 輸入 **□** 鍵, 再輸入 **1** 鍵 → 再按 **Ⓡ** 登記鍵, 密碼登記完成

⚠ 為保障您的安全, 每次自動上鎖後, 請檢查是否正常鎖定.

手動上鎖設定

按 **Ⓡ** 登記鍵 → 在室外部觸摸密碼鍵, 輸入 [#] 鍵 → 在室外部的密碼鍵, 輸入 **□** 鍵, 再輸入 **3** 鍵 → 再按 **Ⓡ** 登記鍵, 密碼登記完成

⚠ 為保障您的安全, 每次開門後, 請檢查是否有將門上鎖.

聲音調節功能

* 原廠設定為大音量

再按 **Ⓡ** 登記鍵 → 在室外部觸摸密碼鍵, 輸入 [#] 鍵 → **無聲** **3**, **0** → 再按 **Ⓡ** 登記鍵, 密碼登記完成
小音量 **3**, **1**
大音量 **3**, **3**

開/關按鈕設定功能

按 **Ⓡ** 登記鍵 ➡ 在室外部觸摸密碼鍵, 輸入[#] 鍵 ➡ 在室外部的密碼鍵, 輸入 **2** 鍵, 再輸入 **4** 鍵 ➡ 再按 **Ⓡ** 登記鍵, 密碼登記完成

- 每輸入一次以上程序,功能就會變更到使用或不使用
- 設定為不使用狀態時,無法使用室內部的開/關按鈕.

警報功能

若未解除的情況下，警報聲會連續發出30分鐘

破壞警報

入侵警報：門上鎖狀態下，從外部破壞門開啟時，會發出警報聲

破壞警報：從外部強制拆解鎖體時，會發出警報

解除入侵/破壞警報

方法1：輸入已登記的密碼或感應卡片

方法2：按室內部的開/關按鈕5秒

高溫警報警報

當內部感應火災高溫時會發生警報，同時自動解除上鎖，方便您逃生

解除高溫警報

方法1：輸入已登記的密碼

方法2：按室內部的開/關按鈕5秒

 若長時間高溫直照產品，有可能啟動高溫警報器

3分鐘自動鎖死功能

- 在[3分鐘自動鎖死]狀態下,不能在室外操作鎖體
- 用未登記的密碼或卡片,連續進行五次錯誤操作,本產品會自動停止即鎖定3分鐘

解除3分鐘自動鎖死

- 方法 1 按室內部的開/關按鈕
- 方法 2 按室內部的 (R) 鍵按鈕
- 方法 3 旋轉室內部的[手動旋鈕]

用虛位密碼開啟

擔心密碼被窺竊時

- 方法 1 用手掌觸摸室內部的密碼鍵 ➡ 虛位密碼 ➡ 已登記密碼 ➡ 用手掌觸摸室內部的密碼鍵
- 方法 2 用手掌觸摸室內部的密碼鍵 ➡ 已登記密碼 ➡ 虛位密碼 ➡ 用手掌觸摸室內部的密碼鍵

- 在[3分鐘自動鎖死]狀態下,不能使用[虛位密碼]開啟,要用已登記的指紋和密碼開啟.
- 在[3分鐘自動鎖死]狀態下,警報功能維持正常.

網路盒

本產品通過簡單的設定，可使用多種功能。
功能升級前請先確認目前正在使用的產品型號

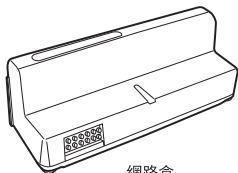

網路盒

安裝網路盒

1 拆下電池

打開室內部的
電池蓋拆下所
有的電池

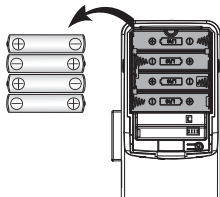

2 安裝網路盒

把網路盒安裝在
網路盒連接部

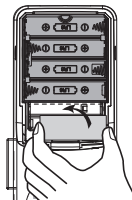

3 安裝電池

確認(+) (-)方向，
再放入全部電池

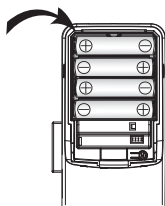





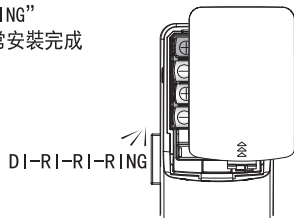







4 確認

“DI-RI-RI-RING”
聲音時，正常安裝完成







遙控器

登記遙控器

順序	操作	具體方法
1 按  登記鍵 ➔  按#鍵	 	取下室內部的電池蓋後, 按  登記鍵後, 再按室外密碼鍵的 
2 按 0 ➔ 按 5	 	按室外密碼鍵的 0 , 5
3 按遙控器的 登記鍵		用針按一下遙控器的 [SET/登記按鈕] (可以連續登記到5個遙控器)
4 按  登記鍵		再按  登記鍵, 登記完成

刪除遙控器

順序	操作	具體方法
1 按  登記鍵 ➔  按#鍵	 	取下室內部的電池蓋後, 按 按  登記鍵後, 再按室外密碼鍵的 
2 按 7 ➔ 按 5	 	按室外密碼鍵的 7 , 5
3 按  登記鍵		再按  登記鍵, 刪除完成

電池耗盡狀況下，從外部提供電源的方法

順序	操作	具體方法
1	接上9V電池 	在室外部的[緊急外接電源接口]，接上9V電池
2	用手掌觸摸密碼鍵 	用手掌觸摸密碼鍵
3	輸入密碼 	輸入已登記的密碼
4	用手掌觸摸密碼鍵或按*鍵 	用手掌觸摸密碼鍵或按 * 鍵。 (正常開啟後，可以拿開9V電池)

更換電池方法

- 電池使用壽命**
本產品使用4顆AA電池，每天使用10次為標準，可使用一年
- 更換電池提示**
使用本產品時，如有提示音響起或警示燈閃爍紅色燈，請更換全部電池

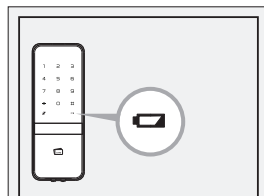

⚠ 請勿使用已用過之電池



<http://www.yalelock.com>